

NOTES:

1) CLOSED CELL EPDM SPONGE RUBBER (0.700 G/CM³)

2) 90 DUROMETER EPDM DENSE RUBBER (1.200 G/CM³)

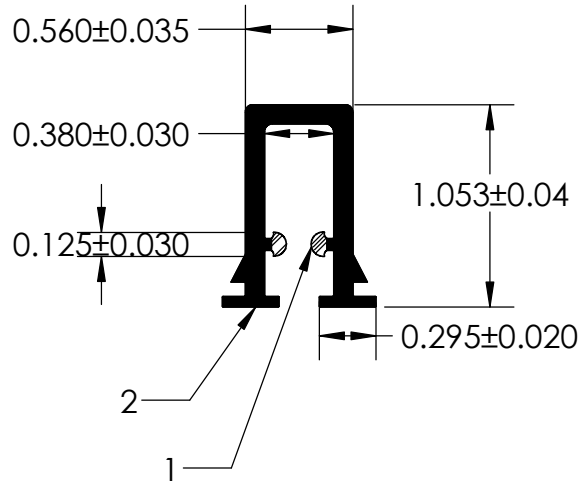
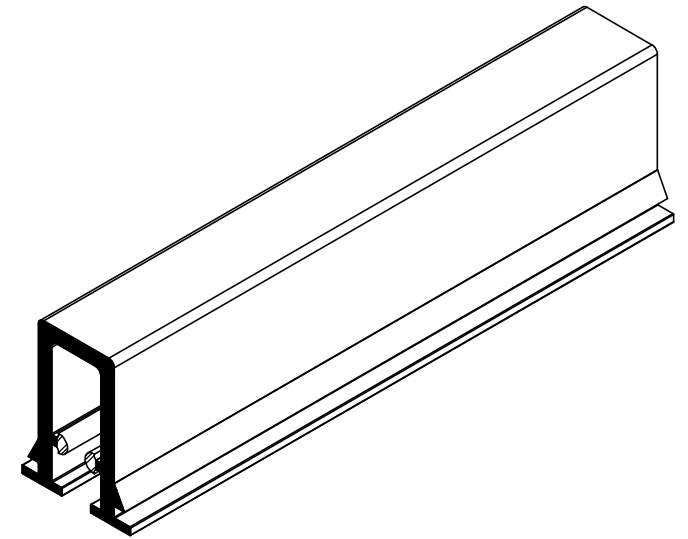

UNI-GRIP, INC.

9823 STATE ROUTE 53 N
UPPER SANDUSKY, OHIO 43351

REVISION BLOCK			
REV.	DATE	REVIEWED BY	CHANGES MADE
A			
B			
C			
D			
E			

PROPRIETARY AND CONFIDENTIAL:

THE INFORMATION CONTAINED IN THIS DRAWING IS THE SOLE PROPERTY OF UNI-GRIP, INC. ANY REPRODUCTION IN PART OR AS A WHOLE WITHOUT THE WRITTEN PERMISSION OF UNI-GRIP, INC. IS PROHIBITED.

DOCUMENT CONTROL NUMBER
UG-1-EN-001-FR-(103018)

UNLESS OTHERWISE SPECIFIED:

DIMENSIONS ARE IN INCHES
TOLERANCES PER ARPM CLASS 3

WEIGHT
0.157 LB/FT

ASTM D1056
2A4

ASTM D2000
3BA711 A14 B13 C12 F17

TITLE: DI-94136		
SIZE A	DWG. NO. UG-1-DU-128	REV
DR. BY C. VENT	DATE 1/22/2020	SHEET 1 OF 1

P:\Engineering\Prints\Dual Durometer\DI-94136 UG-1-DU-128

SCALE: 1:1