

NOTES:

- 1) CLOSED CELL EPDM SPONGE RUBBER (0.700 G/CM<sup>3</sup>)
- 2) 70 DUROMETER EPDM DENSE RUBBER (1.200 G/CM<sup>3</sup>)
- 3) 1.000" WIRE CARRIER (0.021 LB/FT)
- 4) 0.125" VENT HOLE

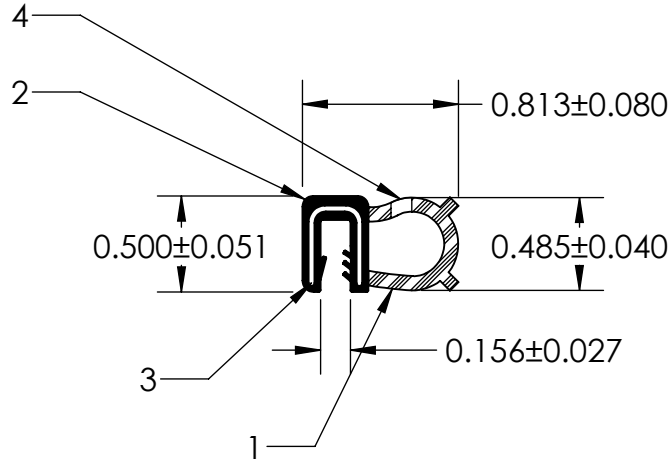
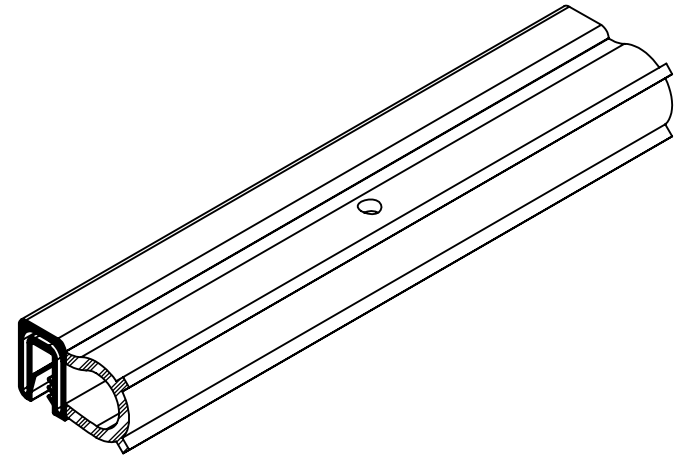

**UNI-GRIP, INC.**

9823 STATE ROUTE 53 N  
UPPER SANDUSKY, OHIO 43351

REVISION BLOCK				PROPRIETARY AND CONFIDENTIAL:	UNLESS OTHERWISE SPECIFIED:	TITLE:				
REV.	DATE	REVIEWED BY	CHANGES MADE	THE INFORMATION CONTAINED IN THIS DRAWING IS THE SOLE PROPERTY OF UNI-GRIP, INC. ANY REPRODUCTION IN PART OR AS A WHOLE WITHOUT THE WRITTEN PERMISSION OF UNI-GRIP, INC. IS PROHIBITED.	DIMENSIONS ARE IN INCHES TOLERANCES PER ARPM CLASS 3	DU-006				
A	1/23/20	K.P.	Changed knit point							
B					WEIGHT	SIZE <b>A</b> DWG. NO. UG-1-DU-1000-WR-006      REV <b>A</b>				
C					ASTM D1056				2A3	
D					DOCUMENT CONTROL NUMBER				ASTM D2000	3BA711 A14 B13 C12 F17
E				UG-1-EN-001-FR-(103018)	SCALE: 1:1					
P:\Engineering\Prints\Dual Durometer\DU-006 UG-1-DU-1000-WR-006				DR. BY	C. VENT	DATE	1/23/2020	SHEET 1 OF 1		