

NOTES:

- 1) CLOSED CELL EPDM SPONGE RUBBER (0.700 G/CM<sup>3</sup>)
- 2) 65 DUROMETER EPDM DENSE RUBBER (1.200 G/CM<sup>3</sup>)
- 3) 1.120" WIRE CARRIER (0.024 LB/FT)
- 4) .125" VENT HOLE EVERY 8-10"
- 5) TIP OF WIPER MUST ALIGN VIRTICALLY WITH OUTER BULB SURFACE +/- 0.080  
BULB TIP MUST FALL IN BOX

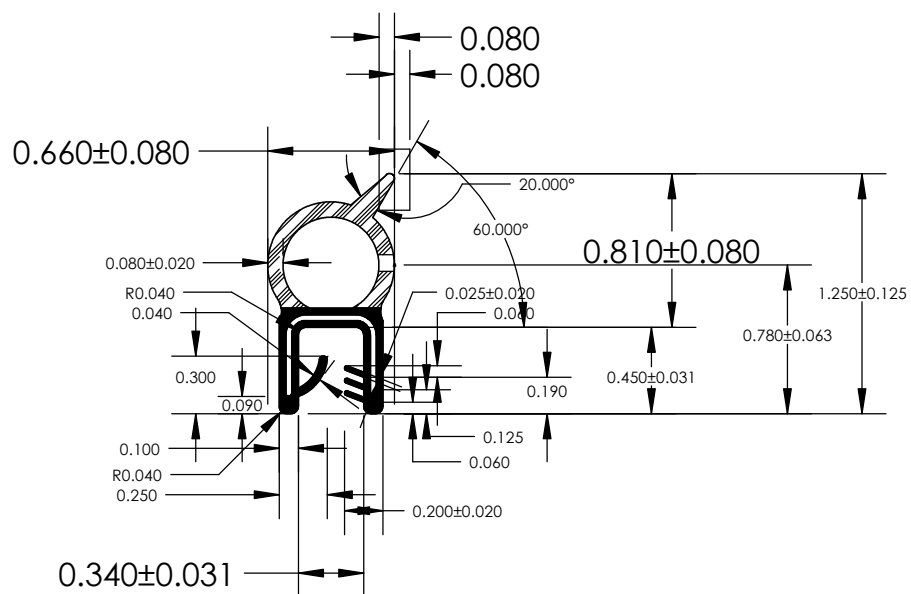

**ANYTHING WITH OUT TOLERANCES IS REFERANCE ONLY**

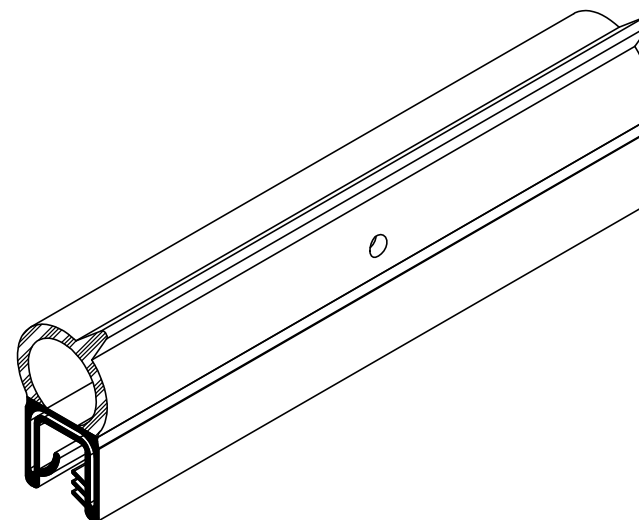

**UNI-GRIP, INC.**

9823 STATE ROUTE 53 N  
UPPER SANDUSKY, OHIO 43351

| REVISION BLOCK  |      |             |              | PROPRIETARY AND CONFIDENTIAL:   | UNLESS OTHERWISE SPECIFIED:                             | TITLE:   |                     |          |         |      |            |              |
|---|------|-------------|--------------|---|---|----------|---------------------|----------|---------|------|------------|--------------|
| REV.  | DATE | REVIEWED BY | CHANGES MADE | THE INFORMATION CONTAINED IN THIS DRAWING IS THE SOLE PROPERTY OF UNI-GRIP, INC. ANY REPRODUCTION IN PART OR AS A WHOLE WITHOUT THE WRITTEN PERMISSION OF UNI-GRIP, INC. IS PROHIBITED. | DIMENSIONS ARE IN INCHES<br>TOLERANCES PER ARPM CLASS 3 | DU-116   |                     |          |         |      |            |              |
| A   |      |             |              |   |   |          |                     |          |         |      |            |              |
| B   |      |             |              |   | WEIGHT  | DU-116   |                     |          |         |      |            |              |
| C   |      |             |              |   | 0.151 LB/FT   |          |                     |          |         |      |            |              |
| D   |      |             |              |   | ASTM D1056  | 2A4      | SIZE                | DWG. NO. | REV     |      |            |              |
| E   |      |             |              | DOCUMENT CONTROL NUMBER   | ASTM D2000  | <b>A</b> | UG-1-DU-1120-WR-116 | <b>A</b> |         |      |            |              |
| P:\Engineering\Prints\Dual Durometer\DU-116 UG-1-DU-1120-WR-116 |      |             |              | UG-1-EN-001-FR-(103018)   | 3BA711 A14 B13 C12 F17                                  | SCALE:   | 1:1                 | DR. BY   | C. VENT | DATE | 10/23/2019 | SHEET 1 OF 1 |