

NOTES:

- 1) CLOSED CELL EPDM SPONGE RUBBER (0.725 G/CM³)
- 2) SD-487 SPRING STEEL CARRIER (0.030 LB/FT)

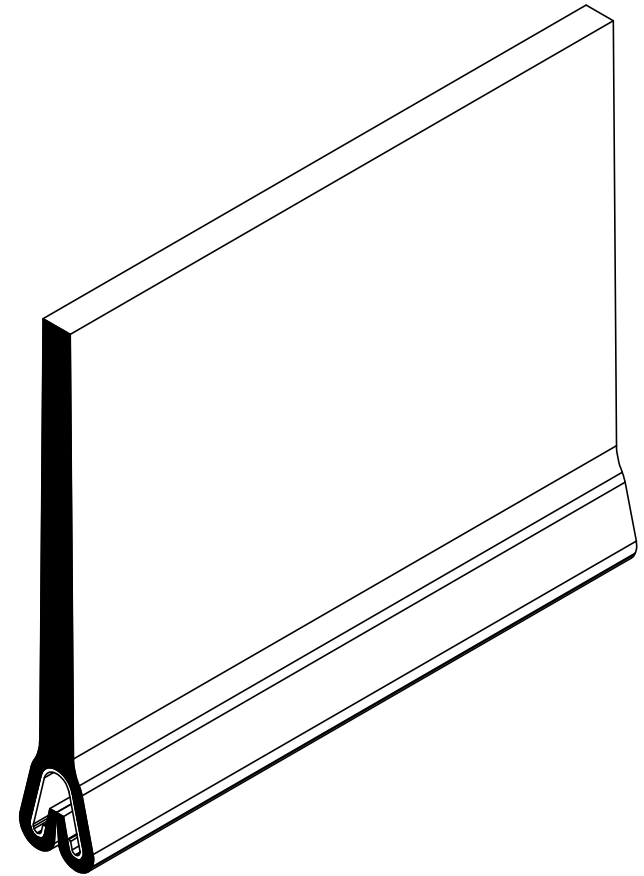
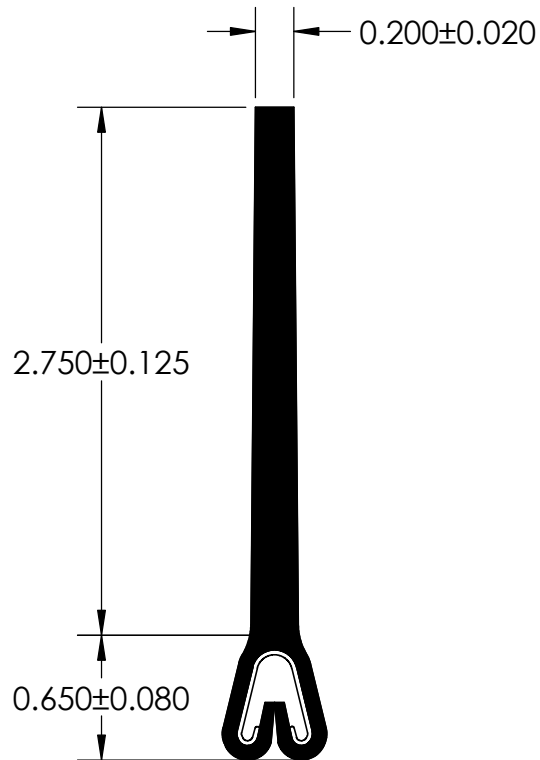

UNI-GRIP, INC.

9823 STATE ROUTE 53 N
UPPER SANDUSKY, OHIO 43351

PROPRIETARY AND CONFIDENTIAL: THE INFORMATION CONTAINED IN THIS DRAWING IS THE SOLE PROPERTY OF UNI-GRIP, INC. ANY REPRODUCTION IN PART OR AS A WHOLE WITHOUT THE WRITTEN PERMISSION OF UNI-GRIP, INC. IS PROHIBITED.	UNLESS OTHERWISE SPECIFIED:	TITLE:	
	DIMENSIONS ARE IN INCHES TOLERANCES PER ARPM CLASS 3	ED-5350	
	WEIGHT 0.295 LB/FT	SIZE A	DWG. NO. UG-1-FL-487-ST-036
DOCUMENT CONTROL NUMBER UG-1-EN-001-FR-(111416)	ASTM D1056 2A3		
	ASTM D2000 N/A	DR. BY C. VENT	DATE 11/3/2017
SCALE: 1:1		SHEET 1 OF 1	