

NOTES:

- 1) CLOSED CELL EPDM SPONGE RUBBER (0.380 G/CM³)
- 2) 80 DUROMETER BLACK PVC (1.370 G/CM³)
- 3) 1.000" STAMPED STEEL (0.046 LB/FT)
- 4) CYANOACRYLATE ADHESIVE

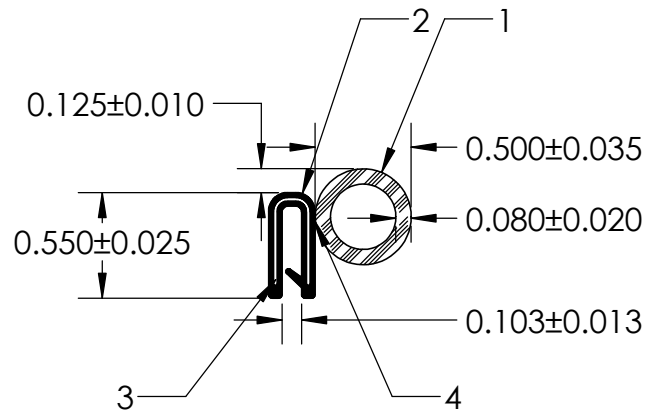
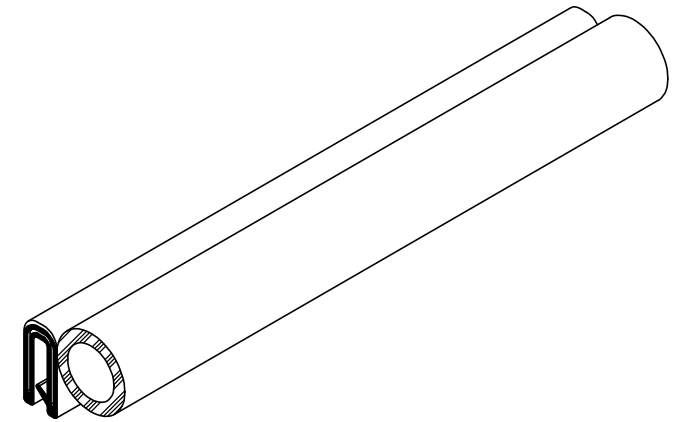

UNI-GRIP, INC.

9823 STATE ROUTE 53 N
UPPER SANDUSKY, OHIO 43351

REVISION BLOCK				PROPRIETARY AND CONFIDENTIAL:	UNLESS OTHERWISE SPECIFIED:	TITLE:			
REV.	DATE	REVIEWED BY	CHANGES MADE	THE INFORMATION CONTAINED IN THIS DRAWING IS THE SOLE PROPERTY OF UNI-GRIP, INC. ANY REPRODUCTION IN PART OR AS A WHOLE WITHOUT THE WRITTEN PERMISSION OF UNI-GRIP, INC. IS PROHIBITED.	DIMENSIONS ARE IN INCHES TOLERANCES PER ARPM CLASS 3	NAV-110			
A									
B					WEIGHT	0.133 LB/FT			
C					ASTM D1056	2A4			
D					DOCUMENT CONTROL NUMBER	ASTM D2000	N/A		
E				UG-1-EN-001-FR-(103018)	SIZE			DWG. NO.	REV
P:\Engineering\Prints\Gkue Line\NAV-110 UG-1-GL-1000FS-025				SCALE:	1:1	A	UG-1-GL-1000-FS-025	A	
				DR. BY	C. VENT	DATE	6/19/2019	SHEET 1 OF 1	