

NOTES:

1) 60 DUROMETER EPDM DENSE RUBBER (1.165 G/CM³)

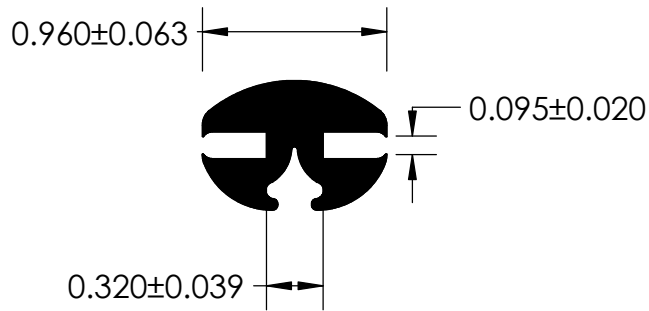
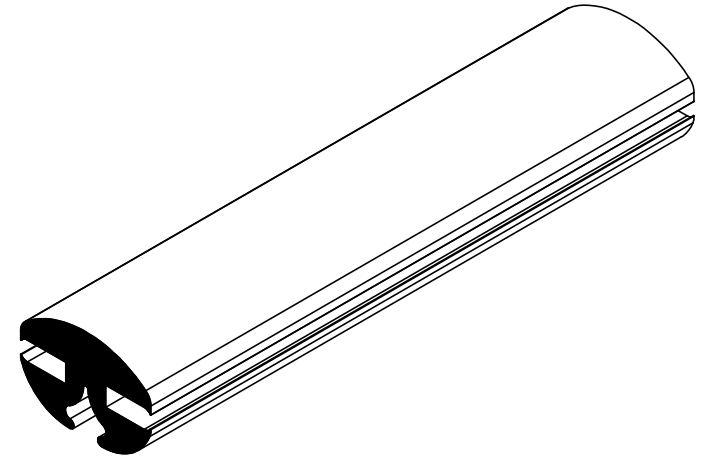

UNI-GRIP, INC.

9823 STATE ROUTE 53 N
UPPER SANDUSKY, OHIO 43351

REVISION BLOCK				PROPRIETARY AND CONFIDENTIAL:	UNLESS OTHERWISE SPECIFIED:	TITLE:				
REV.	DATE	APPROVED BY	CHANGES MADE	THE INFORMATION CONTAINED IN THIS DRAWING IS THE SOLE PROPERTY OF UNI-GRIP, INC. ANY REPRODUCTION IN PART OR AS A WHOLE WITHOUT THE WRITTEN PERMISSION OF UNI-GRIP, INC. IS PROHIBITED.	DIMENSIONS ARE IN INCHES TOLERANCES PER ARPM CLASS 3	RE-028 B				
A	9/26/18	C.V.	INITIAL RELEASE							
B	4/11/19	C.V.	ADDED SUPPORT TIPS		WEIGHT	0.215 LB/FT				
C					ASTM D1056	N/A				
D					DOCUMENT CONTROL NUMBER	ASTM D2000	SIZE	DWG. NO.	REV	
E				UG-1-EN-001-FR-(111416)	3BA711 A14 B13 C12 F17	A	UG-1-RE-028	B		
P:\Engineering\Prints\Rubber Extrusion\RE-028 UG-1-RE-028				SCALE:	1:1	DR. BY	C. VENT	DATE	4/11/2019	SHEET 1 OF 1