

NOTES:

- 1) CLOSED CELL SPONGE (DENSITY 0.536 G/CM³)
- 2) SD-487 SPRING STEEL (0.030 LB/FT)
- 3) 0.125" VENT HOLE 6"-10" SPACING

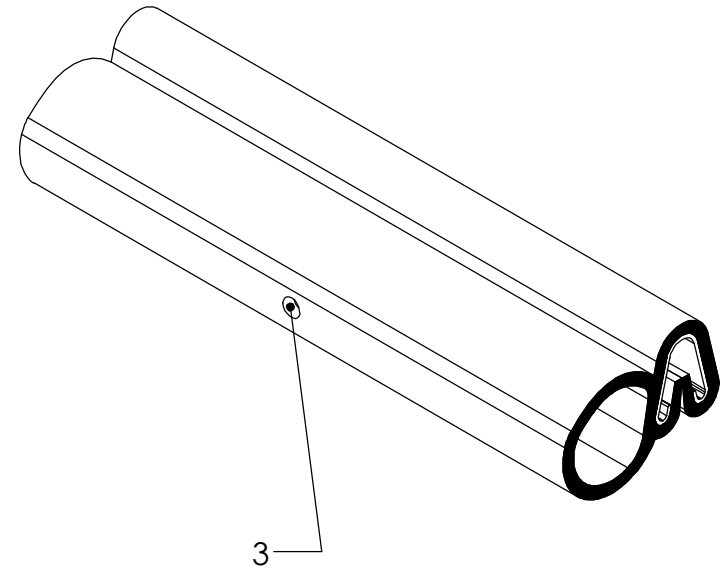
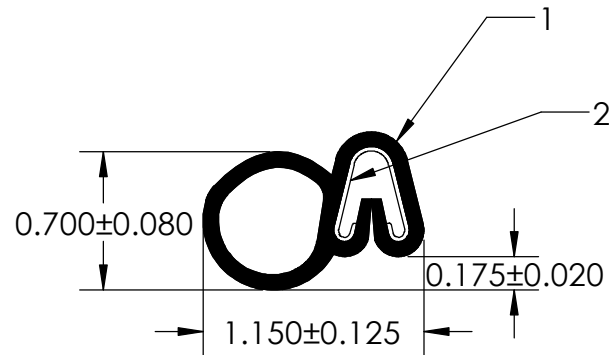

UNI-GRIP, INC.

9823 STATE ROUTE 53 N
UPPER SANDUSKY, OHIO 43351

PROPRIETARY AND CONFIDENTIAL:	UNLESS OTHERWISE SPECIFIED:
THE INFORMATION CONTAINED IN THIS DRAWING IS THE SOLE PROPERTY OF UNI-GRIP, INC. ANY REPRODUCTION IN PART OR AS A WHOLE WITHOUT THE WRITTEN PERMISSION OF UNI-GRIP, INC. IS PROHIBITED.	DIMENSIONS ARE IN INCHES TOLERANCES PER ARPM CLASS 3
	WEIGHT 0.097 LB/FT
	ASTM D1056 2A2
DOCUMENT CONTROL NUMBER UG-1-EN-001-FR-(111416)	ASTM D2000 N/A

TITLE:		SD-109MM	
SIZE A	DWG. NO. UG-1-BL-487-ST-001	REV A	