

NOTES:

- 1) CLOSED CELL EPDM SPONGE RUBBER (0.300 G/CM³)
- 2) 80 DUROMETER BLACK PVC (1.370 G/CM³)
- 3) 1.413" STAMPED ALUMINUM (0.035 LB/FT)

CUT LENGTH	TOLERANCES
87.6"	+/- 0.40"
28.248"	+/- 0.20"
71.196"	+/- 0.40"
24.996"	+/- 0.20"
30.132"	+/-0.20"

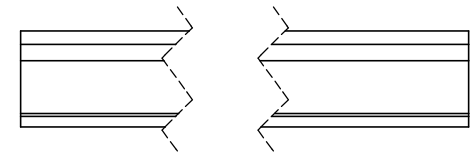
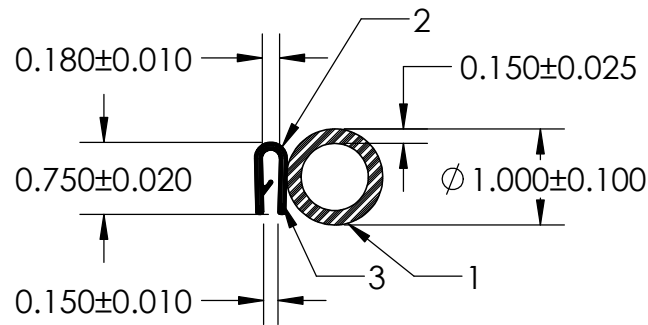
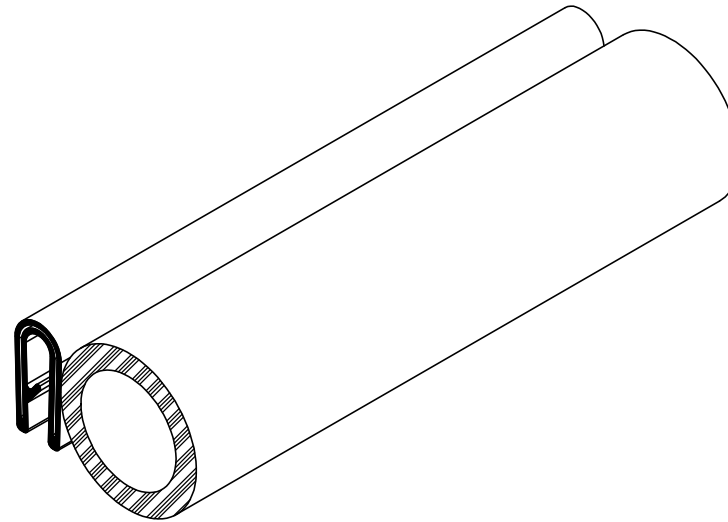

UNI-GRIP, INC.

9823 STATE ROUTE 53 N
UPPER SANDUSKY, OHIO 43351

REVISION BLOCK			
REV.	DATE	REVIEWED BY	CHANGES MADE
A			
B			
C			
D			
E			

PROPRIETARY AND CONFIDENTIAL:	UNLESS OTHERWISE SPECIFIED:
THE INFORMATION CONTAINED IN THIS DRAWING IS THE SOLE PROPERTY OF UNI-GRIP, INC. ANY REPRODUCTION IN PART OR AS A WHOLE WITHOUT THE WRITTEN PERMISSION OF UNI-GRIP, INC. IS PROHIBITED.	DIMENSIONS ARE IN INCHES TOLERANCES PER ARPM CLASS 3
DOCUMENT CONTROL NUMBER UG-1-EN-001-FR-(103018)	WEIGHT ASTM D1056 2A3 ASTM D2000 N/A

TITLE:		
SD-1400-AL w/ 1" BULB		
SIZE A	DWG. NO. UG-1-GL-1430-AL-031	REV