

NOTES:

- 1) CLOSED CELL EPDM SPONGE RUBBER (0.750 G/CM³)
- 2) SD-487 SPRING STEEL CARRIER (0.030 LB/FT)

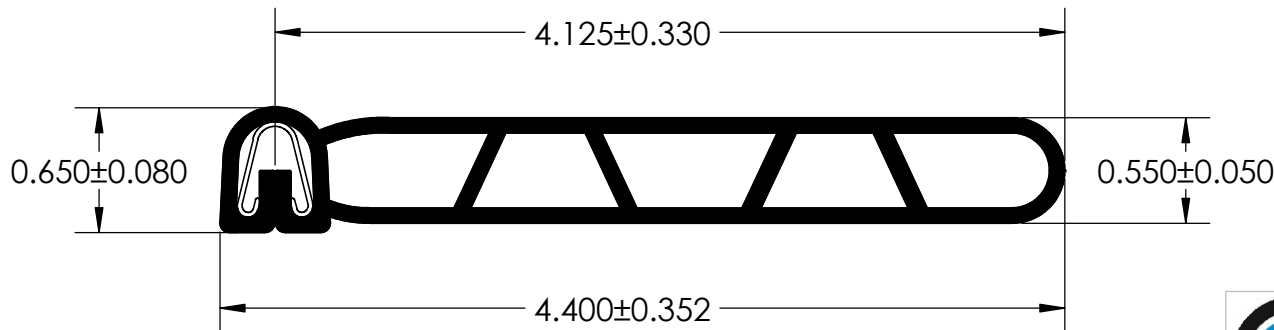
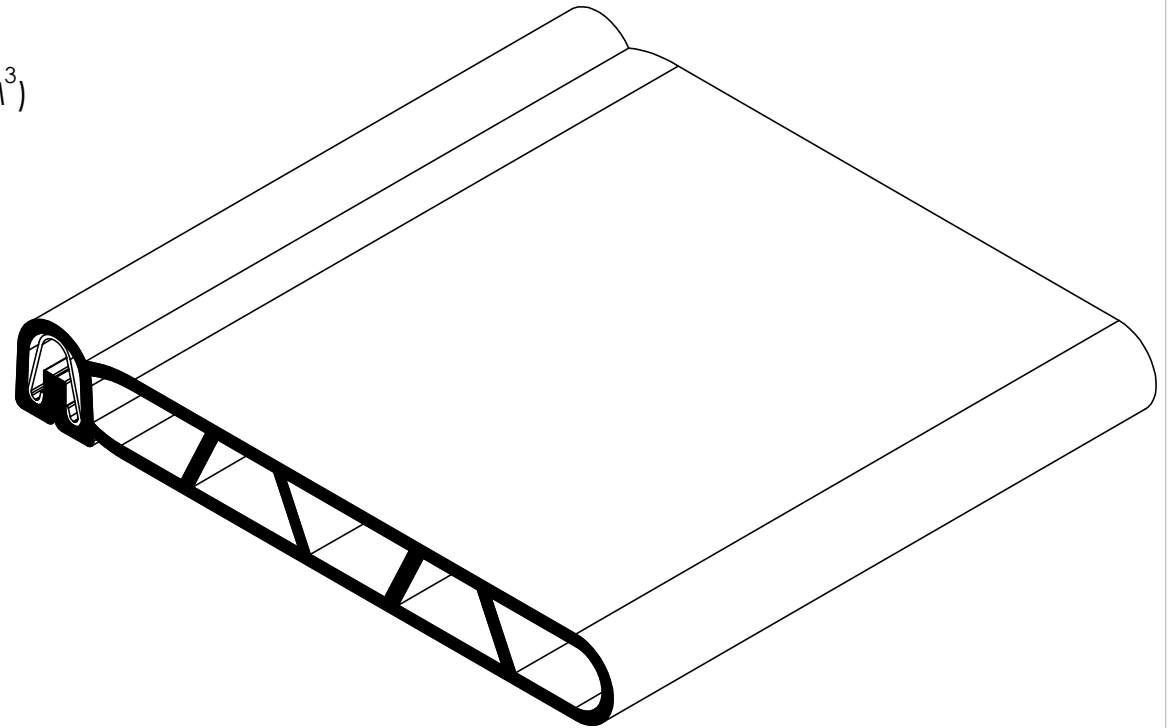

UNI-GRIP, INC.

9823 STATE ROUTE 53 N
UPPER SANDUSKY, OHIO 43351

REVISION BLOCK				PROPRIETARY AND CONFIDENTIAL:	UNLESS OTHERWISE SPECIFIED:	TITLE:				
REV.	DATE	REVIEWED BY	CHANGES MADE	THE INFORMATION CONTAINED IN THIS DRAWING IS THE SOLE PROPERTY OF UNI-GRIP, INC. ANY REPRODUCTION IN PART OR AS A WHOLE WITHOUT THE WRITTEN PERMISSION OF UNI-GRIP, INC. IS PROHIBITED.	DIMENSIONS ARE IN INCHES TOLERANCES PER ARPM CLASS 3	SD-515				
A										
B					WEIGHT	0.468 LB/FT				
C					ASTM D1056	2A4				
D					DOCUMENT CONTROL NUMBER	ASTM D2000	N/A			
E				UG-1-EN-001-FR-(103018)						
P:\Engineering\Prints\Bulb Seals\SD-515 UG-1-BL-487-ST-075				SCALE:	1:1	DR. BY	C. VENT	DATE	10/28/2019	SHEET 1 OF 1